

# Installation Guide

Avigilon™ HD Multisensor Dome Camera Models:

12W-H3-4MH-DC1 and 9W-H3-3MH-DC1

# Important Safety Information

This manual provides installation and operation information and precautions for the use of this camera. Incorrect installation could cause an unexpected fault. Before installing this equipment read this manual carefully. Please provide this manual to the owner of the equipment for future use.



The Warning symbol indicates the presence of dangerous voltage within and outside the product enclosure that may constitute a risk of electric shock, serious injury or death to persons if proper precautions are not followed.



The Caution symbol alerts the user to the presence of hazards that may cause minor or moderate injury to persons, damage to property or damage to the product itself if proper precautions are not followed.



**WARNING** — Failure to observe the following instructions may result in severe injury or death.

- Installation must be performed by qualified personnel only, and must conform to all local codes.
- This product is intended to be supplied by a UL Listed Power Unit marked “Class 2” or “LPS” or “Limited Power Source” with output rated 24 VAC +/- 10%, 19 VA min.; 24 VDC +/- 10%, 13 W min. or Power over Ethernet (PoE) Plus IEEE802.3at Type 2 compliant Power Sourcing Equipment (PSE) rated 44-57 VDC, 13W min.
- Any external power supply connected to this product may only be connected to another Avigilon product of the same model series. External power connections must be properly insulated.
- Do not connect directly to mains power for any reason.



**CAUTION** — Failure to observe the following instructions may result in injury or damage to the camera.

- Do not install near any heat sources such as radiators, heat registers, stoves, or other sources of heat.
- Do not subject the cables to excessive stress, heavy loads or pinching.
- Do not open or disassemble the device. There are no user serviceable parts.
- Refer all servicing to qualified personnel. Servicing may be required when the device has been damaged (such as from a liquid spill or fallen objects), has been exposed to rain or moisture, does not operate normally, or has been dropped.
- Do not use strong or abrasive detergents when cleaning the device body.
- Use only accessories recommended by Avigilon.

## Regulatory Notices

This device complies with part 15 of the FCC Rules. Operation is subject to the following two conditions: (1) This device may not cause harmful interference, and (2) this device must accept any interference received, including interference that may cause undesired operation.

This Class B digital apparatus complies with Canadian ICES-003.

## FCC Notice

This equipment has been tested and found to comply with the limits for a Class B digital device, pursuant to Part 15 of the FCC rules. These limits are designed to provide reasonable protection against harmful interference in a residential installation. This equipment generates, uses and can radiate radio frequency energy and, if not installed and used in accordance with the instructions, may cause harmful interference to radio communications. However, there is no guarantee that interference will not occur in a particular installation. If this equipment does cause harmful interference to radio or television reception, which can be determined by turning the equipment off and on, the user is encouraged to try to correct the interference by one or more of the following measures:

- Reorient or relocate the receiving antenna.
- Increase the separation between the equipment and the receiver.
- Connect the equipment into an outlet on a circuit different from that to which the receiver is connected.
- Consult the dealer or an experienced radio/TV technician for help.

Changes or modifications made to this equipment not expressly approved by Avigilon Corporation or parties authorized by Avigilon Corporation could void the user's authority to operate this equipment.

## Disposal and Recycling Information

When this product has reached the end of its useful life, please dispose of it according to your local environmental laws and guidelines.

Risk of fire, explosion, and burns. Do not disassemble, crush, heat above 100 °C (212 °F), or incinerate.

### European Union:



This symbol means that according to local laws and regulations your product should be disposed of separately from household waste. When this product reaches its end of life, take it to a collection point designated by local authorities. Some collection points accept products for free. The separate collection and recycling of your product at the time of disposal will help conserve natural resources and ensure that it is recycled in a manner that protects human health and the environment.

## Legal Notices

© 2015, Avigilon Corporation. All rights reserved. AVIGILON, the AVIGILON logo, and AVIGILON CONTROL CENTER are trademarks of Avigilon Corporation. Other product names mentioned herein may be the trademarks of their respective owners. The absence of the symbols ™ and ® in proximity to each trademark in this product or its packaging is not a disclaimer of ownership of the related trademark. Unless expressly granted in

writing, no license is granted with respect to any copyright, industrial design, trademark, patent or other intellectual property rights of Avigilon Corporation or its licensors.

## Disclaimer

This document has been compiled and published covering the latest product descriptions and specifications. The contents of this document and the specifications of the products discussed herein are subject to change without notice. Neither Avigilon Corporation nor any of its affiliated companies guarantees the completeness or accuracy of the information contained in this document and is not responsible for your use of, or reliance on, the information. Avigilon Corporation shall not be responsible for any losses or damages (including consequential damages) caused by reliance on the information presented herein.

Avigilon Corporation  
<http://www.avigilon.com>

PDF-H3-MH-DC-A

Revision: 2 - EN

20150820

# Table of Contents

Overview .....	1
Front View .....	1
Side View .....	2
Installation .....	4
Camera Package Contents .....	4
Installation Steps .....	4
Preparing the Camera for Installation .....	4
(Optional) Cutting the Mounting Hole .....	6
(Optional) Configuring Onboard Storage .....	6
(Optional) Attaching the Back Panel .....	7
Connecting Cables .....	8
Assigning an IP Address .....	8
Accessing the Live Video Stream .....	9
Mounting the Dome Camera .....	9
Aiming the Dome Camera .....	10
Installing the Dome Cover .....	12
For More Information .....	12
Cable Connections .....	13
Connecting External Power .....	13
Connecting to External Devices .....	13
Connecting to Microphone and Speakers .....	14
LED Indicators .....	16
Resetting to Factory Default Settings .....	17
Setting the IP Address Using the ARP/Ping Method .....	18
Cleaning .....	19
Dome Bubble .....	19
Body .....	19
Specifications .....	20
Limited Warranty & Technical Support .....	22

# Overview

## Front View

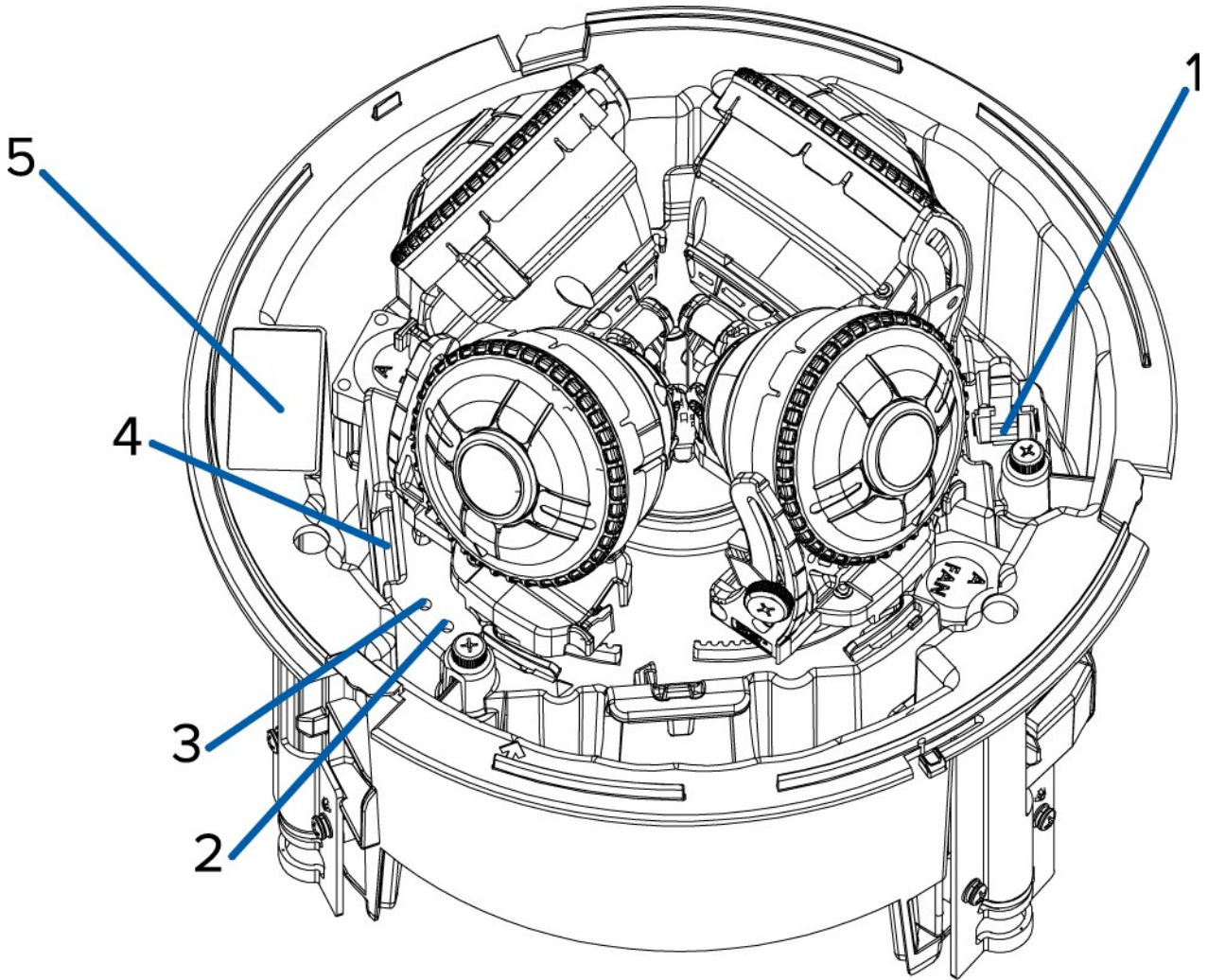

**1. Configuration Ethernet Port**

A secondary Ethernet port for configuring the camera. Does not accept PoE.

**2. Link LED**

Indicates if there is an active connection in the Ethernet port.

**3. Connection Status LED**

Provides information about device operation. For more information, see *LED Indicators* on page 16

**4. SD Card Slot**

Accepts an SD card for onboard storage.

## 5. Serial Number Tag

Product serial number and part number label.

## Side View

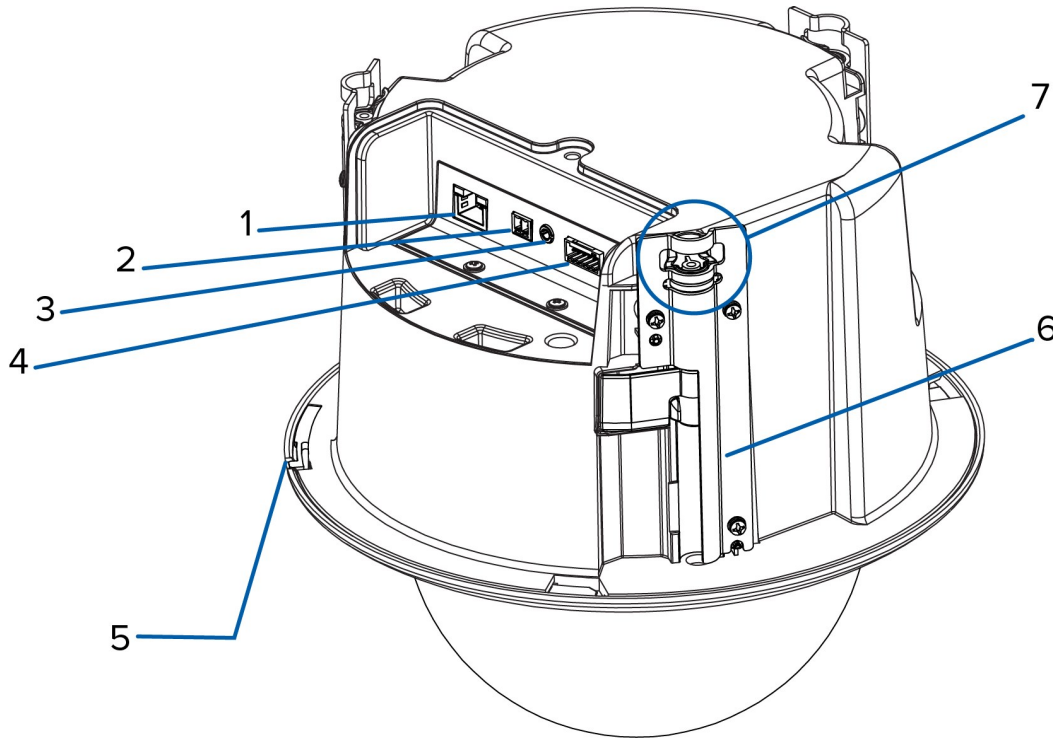

### 1. Ethernet Port

Accepts an Ethernet connection to a network. Server communication and image data transmission occurs over this connection. Also receives power when it is connected to a network that provides Power over Ethernet.

### 2. Power Connector Block

Accepts a terminal block with either an AC or DC power connection. DC input can be either polarity. Only required when Power over Ethernet is not available.

### 3. Audio I/O Connector

Accepts a mini-jack connector (3.5 mm).

### 4. I/O Connector Block

Provides connections to external input/output devices.

### 5. Cover Release Tab

Allows you to release and remove the dome cover.

## 6. **Clamps**

Three spring loaded locking mechanisms that secure the camera to the mounting surface.

## 7. **Lanyard Anchor**

Safety lanyards can attach to anchors at the top of each clamp to help prevent the camera from falling.



# Installation

## Camera Package Contents

Ensure the package contains the following:

- Avigilon™ HD Multisensor Dome Camera
- Back panel
- Phillips screw driver
- Mounting template sticker
- Terminal block
- I/O connector block

## Installation Steps

Complete the following steps to install the device:

---

<i>Preparing the Camera for Installation</i> .....	4
<i>(Optional) Cutting the Mounting Hole</i> .....	6
<i>(Optional) Configuring Onboard Storage</i> .....	6
<i>(Optional) Attaching the Back Panel</i> .....	7
<i>Connecting Cables</i> .....	8
<i>Assigning an IP Address</i> .....	8
<i>Accessing the Live Video Stream</i> .....	9
<i>Mounting the Dome Camera</i> .....	9
<i>Aiming the Dome Camera</i> .....	10
<i>Installing the Dome Cover</i> .....	12

### Preparing the Camera for Installation

**NOTE:** Be careful not to scratch the dome bubble.

1. Place the camera on a flat surface with the dome facing up.
2. Press the cover release tab and twist the dome cover until it is released from the base.

The dome cover can only move in one direction.

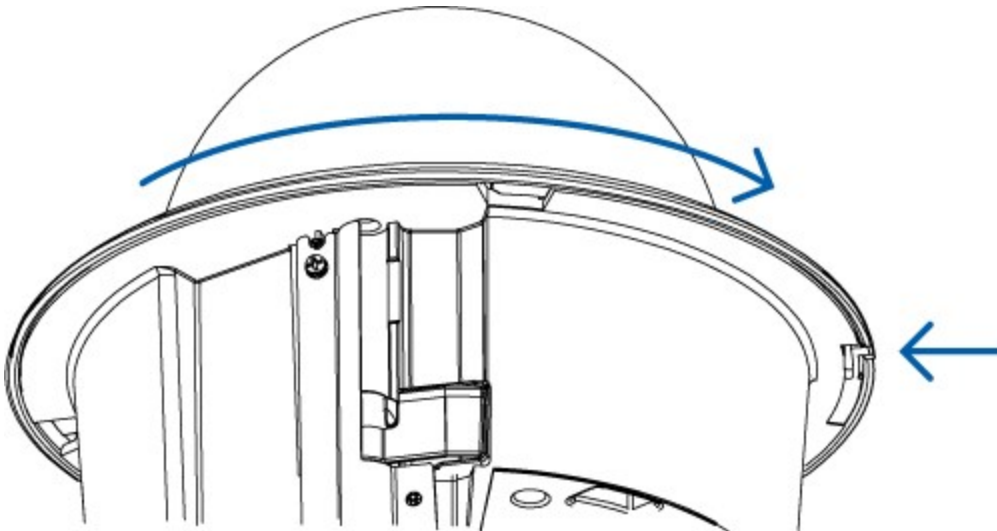
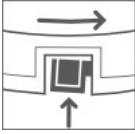

3. Remove the protective material inside the dome cover.
4. Using the provided screw driver, push each of the clamps into the dome camera until the spring is fully compressed, then turn the clamp into the ready position.

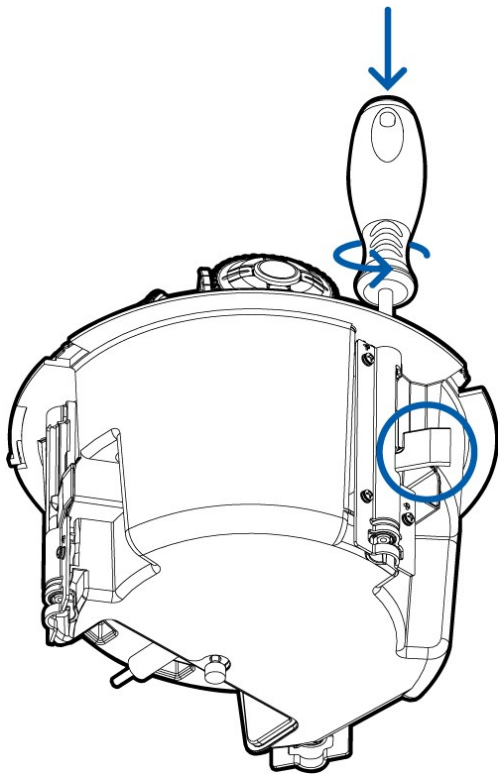

**Figure 1:** Setting the clamp into ready position.

### **(Optional) Cutting the Mounting Hole**

This procedure is not required if you are planning to install the camera with a metal ceiling panel.

1. Use the mounting template to cut a hole in the mounting surface.
2. Remove the mounting template and pull the required cables through the mounting hole.

### **(Optional) Configuring Onboard Storage**

To use the camera's onboard storage feature, you must insert an SD card into the SD card slot.

It is recommended that the SD card have a capacity of 8GB or more, and a write speed of class 6 or better. If the SD card does not meet the recommended capacity or write speed, the performance of the onboard storage may suffer and result in the loss of frames or footage.

1. Loosen the screws that secure the camera module to the base.
2. Lift the camera module out of the base until the SD card slot is exposed. The camera module will only lift up about 2cm or about 1" off the base because it is anchored behind the camera module. Do not pull too hard.

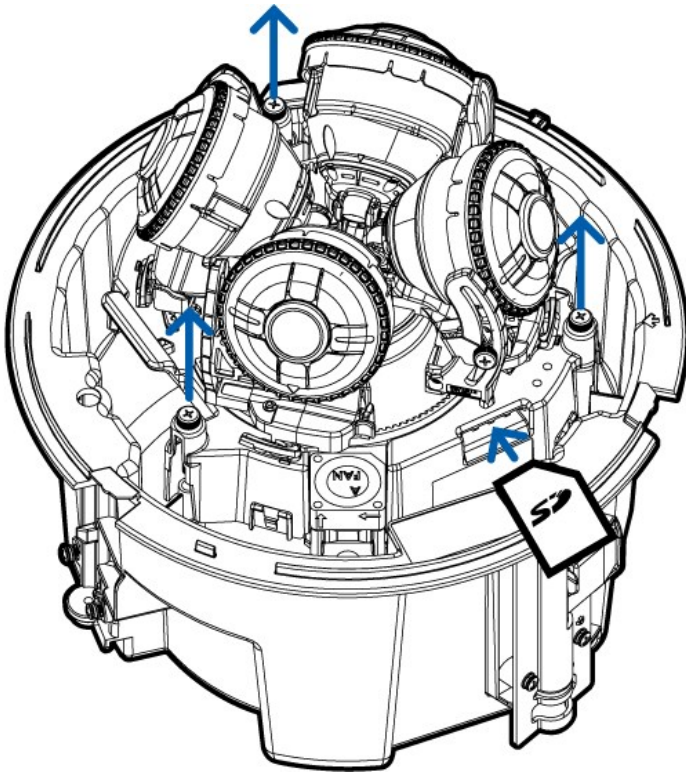

3. Insert an SD card into the camera.



**CAUTION** — Do not force the SD card into the camera or you may damage the card and the camera. The SD card can only be inserted in the orientation shown on the camera.

4. Push the camera module back into the base and tighten the screws
5. Access the camera's web interface to enable the onboard storage feature. For more information, see the *Avigilon High Definition H.264 Camera Web Interface User Guide*.

### **(Optional) Attaching the Back Panel**

If you are installing the dome camera into a plenum space, install the back panel.

1. Attach a conduit connector to the cable entry hole on the back panel. Install the conduit and its fitting as instructed by the manufacturer.

2. Pull the required cables through the conduit, then through the cable entry hole in the back panel.

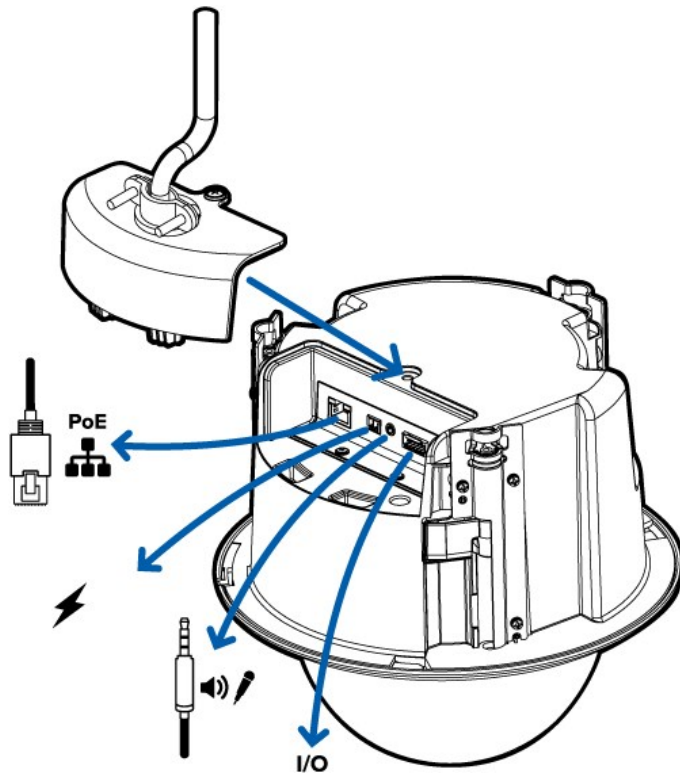

3. After you make the cable connections, screw the back panel into place.

## Connecting Cables

Refer to the diagrams in the Overview section for the location of the different connectors.

To connect the cables required for proper operation, complete the following:

1. If external input or output devices are part of the installation (for example: door contacts, relays, etc), connect the devices to the I/O Terminals.
2. If an external microphone or speaker is required, connect the devices to the audio connector.
3. Connect power using one of the following methods:
  - Power over Ethernet (PoE) Class 3 — Connect a PoE compliant injector or switch to the Ethernet network cable.
  - External Power — Connect an external “Class 2” or “LPS” or “Limited Power Source” with output rated 24 V AC +/- 10%, 19 VA minimum or 24 V DC +/- 10%, 13 W minimum.
4. Connect a network cable to the Ethernet Port (RJ-45 connector).

The Link LED will turn on once a network link has been established.
5. Check that the Connection Status LED indicates the correct state. For more information, see *LED Indicators* on page 16.

## Assigning an IP Address

The camera automatically obtains an IP address when it is connected to a network.

**NOTE:** If the camera cannot obtain an IP address from a DHCP server, it will use Zero Configuration Networking (Zeroconf) to choose an IP address. When set using Zeroconf, the IP address is in the 169.254.0.0/16 subnet.

The IP address settings can be changed using one of the following methods:

- Camera's web browser interface: `http://<camera IP address>/`
- ARP/Ping method. For more information, see *Setting the IP Address Using the ARP/Ping Method* on page 18
- Network Video Management software application (for example, Avigilon™ Control Center).

**NOTE:** The default camera username is `admin` and the default password is `admin`.

## Accessing the Live Video Stream

Live video stream can be viewed using one of the following methods:

- Web browser interface: `http://<IP address>/`
- Network Video Management software application (for example, the Avigilon Control Center software).

**NOTE:** The default camera username is `admin` and the default camera password is `admin`.

## Mounting the Dome Camera

After the cable connections have been made, mount the dome camera.

1. (Recommended) Attach a safety lanyard from the mounting surface to each of the lanyard anchors to help prevent the camera from falling.
2. Push the dome camera into the mounting hole.

3. Use the provided screw driver and release the clamps to secure the camera into place.

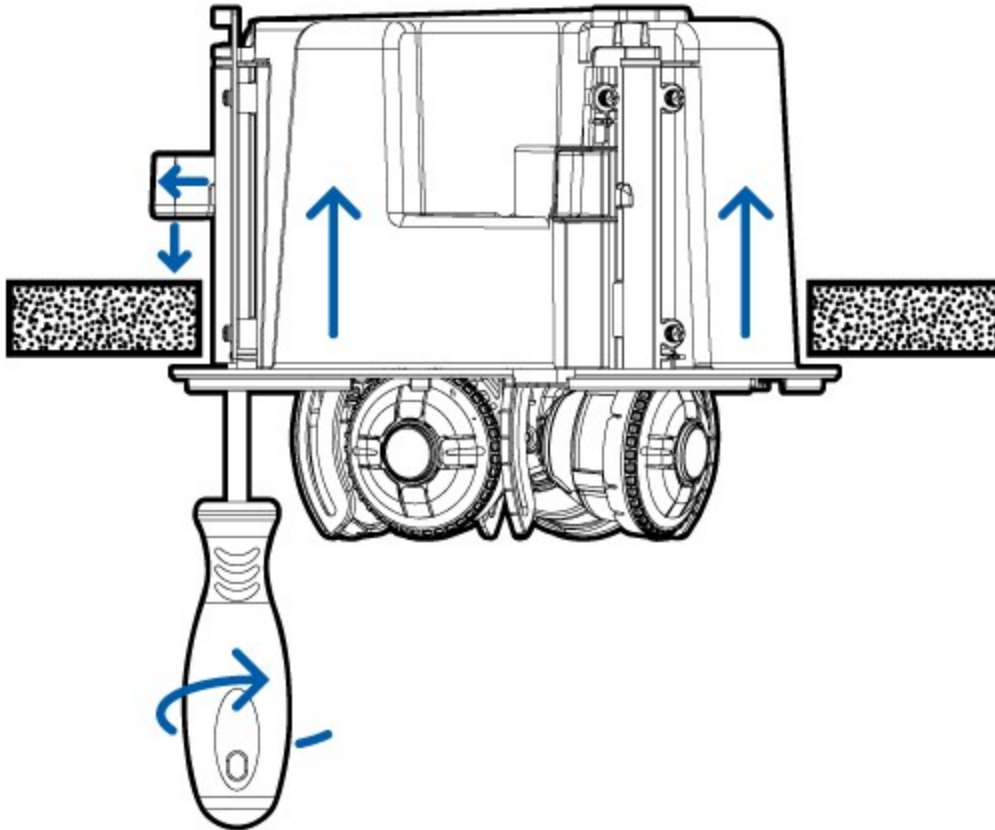

### Aiming the Dome Camera

1. (Optional) To help you aim the dome camera, you can connect an Ethernet cable to the Configuration Ethernet Port.

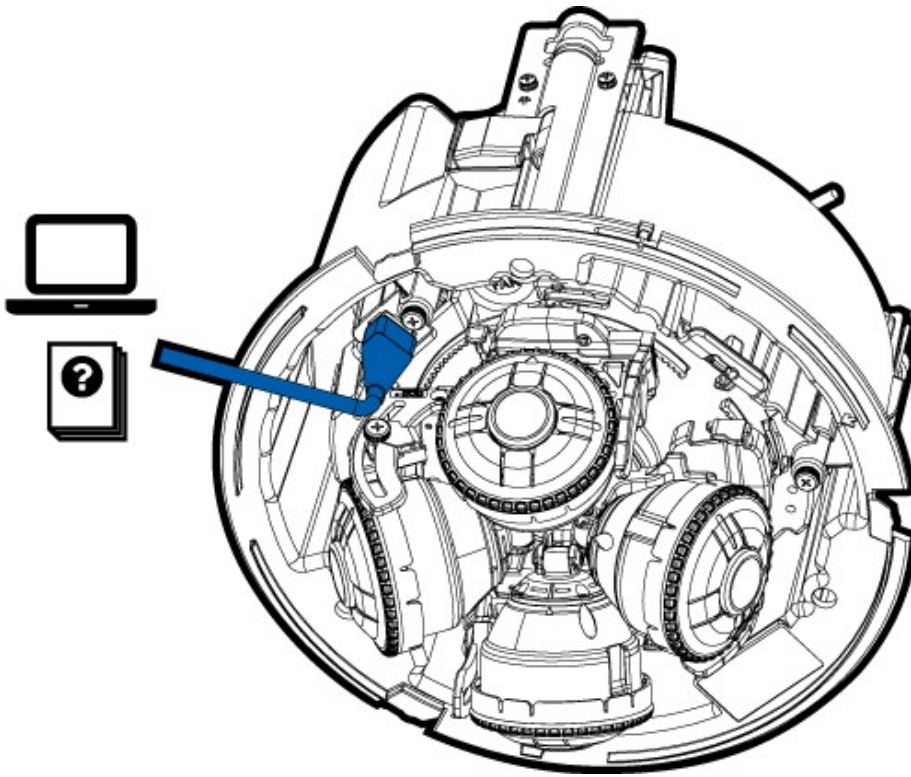

Be aware that while the Configuration Ethernet Port is in use, the primary Ethernet port will only be used for PoE.

**Important:** While the Configuration Ethernet Port is in use, the camera will only stream video and accept commands from the Configuration Ethernet Port. Also, the Indicator LEDs will only show the connection status for this Ethernet port.



2. To aim the camera, adjust each of the available camera heads as required:

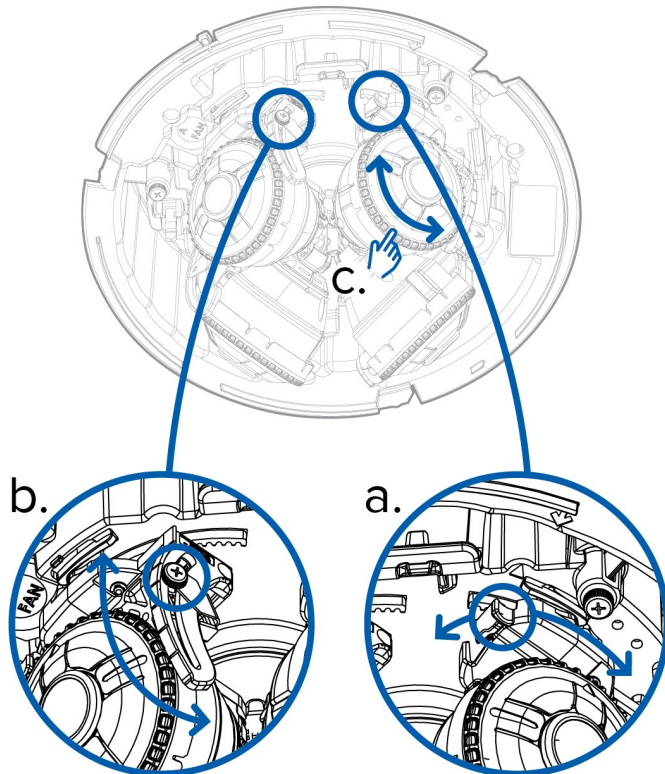

- a. Press the rail release tab to move the camera head side to side.
  - b. Loosen the tilt lock screws to tilt each camera head up and down. Lock the screws when the camera is tilted in the correct angle.
  - c. Rotate the azimuth control ring to set the image in the correct rotation.
3. In the camera web browser interface, adjust the camera's Image and Display settings to achieve the desired zoom position.

### Installing the Dome Cover

1. Align the notches on the dome cover with the release tab on the base. The dome cover should be flush against the camera base.
2. Slide the dome cover clockwise until it locks into place.

**NOTE:** Be careful not to scratch the dome bubble.

### For More Information

Additional information about setting up and using the device is available in the following guides:

- *Avigilon™ Control Center Client User Guide*
- *Avigilon™ High Definition H.264 Web Interface User Guide*

The manuals are available on the Avigilon website: <http://avigilon.com/support-and-downloads>

# Cable Connections

## Connecting External Power

**NOTE:** Do not perform this procedure if Power over Ethernet (POE) is used.

If PoE is not available, the device needs to be powered through the removable power connector block. Refer to the diagrams in this guide for the location of the power connector block.

The device can be powered from 12 V DC or 24 V AC. The power consumption information is listed in the product specifications.

To connect power to the power connector block, complete the following steps:

1. Remove the power connector block from the device.
2. Remove the insulation from  $\frac{1}{4}$ " (6 mm) of the power wires. Do not nick or damage the wires.
3. Insert the two power wires into the two terminals on the power connector block. The connection can be made with either polarity.

Use a small slotted ( $\frac{5}{64}$ " or 2 mm blade width) screwdriver to loosen and tighten the terminals.

4. Attach the power connector block back into the receptacle on the device.



**WARNING** — This product is intended to be supplied by a UL Listed Power Unit marked “Class 2” or “LPS” or “Limited Power Source” with output rated 24 V AC +/- 10%, 19 VA min. or 24 V DC +/- 10%, 13 W min.

## Connecting to External Devices

External devices are connected to the device through the I/O terminal. The pinout for the I/O terminal is shown in the following diagram:

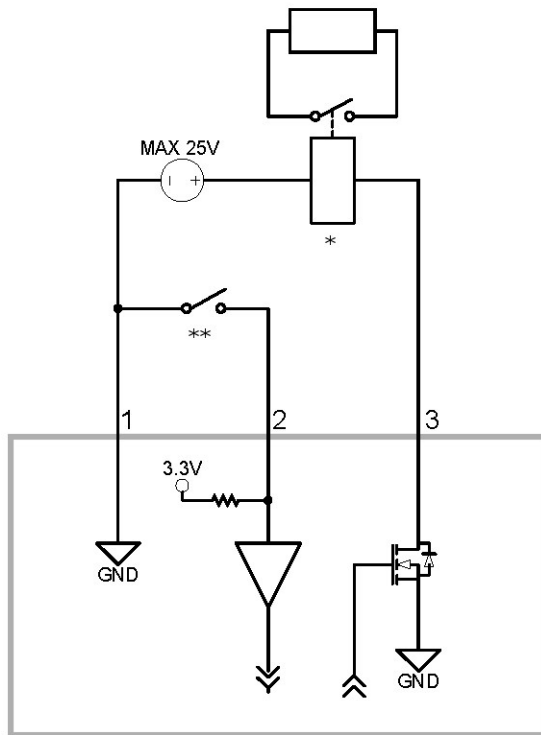

1. Ground
2. Input — To activate, connect the Input to the Ground pin. To deactivate, leave disconnected or apply between 3-15 V.
3. Output — When active, Output is internally connected with the Ground pin. Circuit is open when inactive. Maximum load is 25 VDC, 120 mA.
4. \* — Relay
5. \*\* — Switch

Not connected – position 4,5 and 6.

## Connecting to Microphone and Speakers

The camera can be connected to an external microphone and speaker through the audio connector. The connector is a mini-jack (3.5 mm), and the pinout for it is shown in the following diagram.

**NOTE:** The camera only supports line level mono audio input.

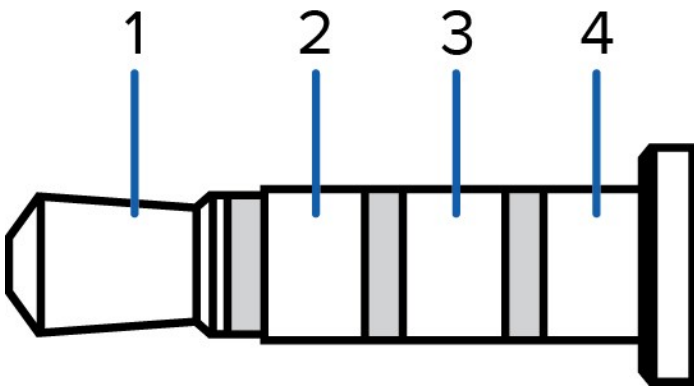

1. Audio IN
2. Audio OUT
3. GND
4. GND

# LED Indicators

Once connected to the network, the Connection Status LED will display the progress in connecting to the Network Video Management software.

The following table describes what the LEDs indicate:

<b>Connection State</b>	<b>Connection Status LED</b>	<b>Description</b>
Obtaining IP Address	One short flash every second	Attempting to obtain an IP address.
Discoverable	Two short flashes every second	Obtained an IP address but is not connected to the Network Video Management software.
Upgrading Firmware	Two short flashes and one long flash every second	Updating the firmware.
Connected	On	Connected to the Network Video Management software.

# Resetting to Factory Default Settings

If the camera no longer functions as expected, you can choose to reset the camera to its factory default settings.

Use the firmware revert button to reset the camera.

**NOTE:** Be careful not to scratch the dome bubble.

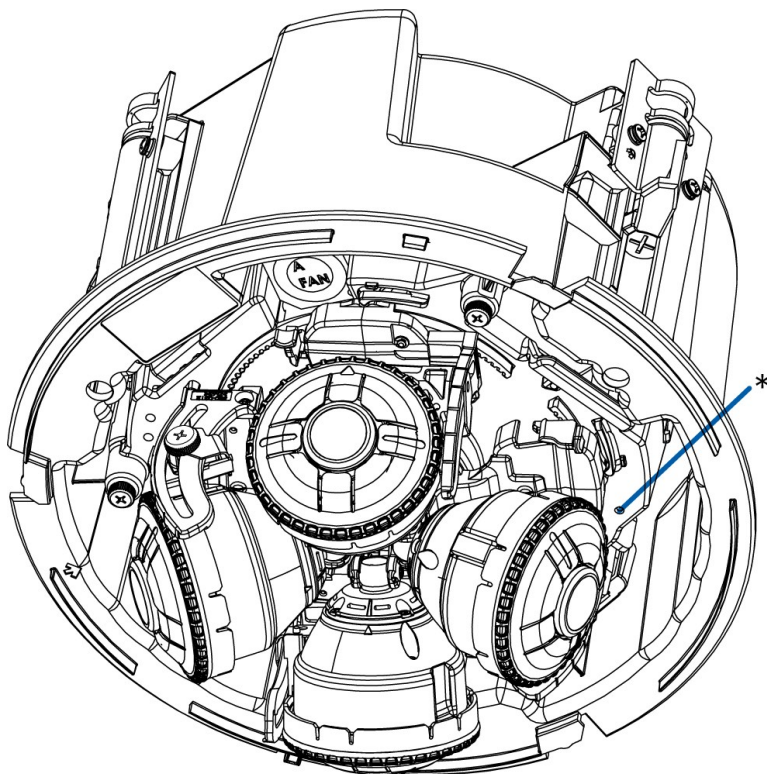

**Figure 2:** The firmware revert button.

1. Ensure the camera is powered on.
2. Remove the dome cover.
3. Using a straightened paperclip or similar tool, gently press and hold the firmware revert button for two seconds.
4. Re-install the dome cover.



**CAUTION** — Do not apply excessive force. Inserting the tool too far will damage the device.

# Setting the IP Address Using the ARP/Ping Method

Complete the following steps to configure the camera to use a specific IP address:

1. Locate and copy down the MAC Address (MAC) listed on the Serial Number Tag for reference.
2. Open a Command Prompt window and enter the following commands:
  - a. `arp -s <New Camera IP Address> <Camera MAC Address>`  
For example: `arp -s 192.168.1.10 00-18-85-12-45-78`
  - b. `ping -l 123 -t <New Camera IP Address>`  
For example: `ping -l 123 -t 192.168.1.10`
3. Reboot the camera.
4. Close the Command prompt window when you see the following message:  
`Reply from <New Camera IP Address>: ...`

# Cleaning

## Dome Bubble

If the video image becomes blurry or smudged in areas, it may be because the dome bubble requires cleaning.

To clean the dome bubble:

- Use hand soap or a non-abrasive detergent to wash off dirt or finger prints
- Use a microfiber cloth or non-abrasive fabric to dry the dome bubble.

**Important:** Failure to use the recommended cleaning materials may result in a damaged or scratched dome bubble that will negatively impact image quality and result in unwanted IR light reflecting into the lens.

## Body

- Use a dry or lightly dampened cloth to clean the camera body.

Do not use strong or abrasive detergents.





# Specifications

## Camera

Lens	12W-H3-4MH-DC1 – 4 x 3MP 2.8-8 mm, F1.3, P-iris 9W-H3-3MH-DC1 – 3 x 3MP 2.8-8 mm, F1.3, P-iris
Audio Input/Output	Line level input and output
Onboard Storage	SD/SDHC/SDXC slot – minimum class 4; class 6 or better recommended

## Network

Network	100Base-TX
Cabling Type	CAT5
Connector	RJ-45
ONVIF	ONVIF compliance version 1.02, 2.00, Profile S ( <a href="http://www.onvif.org">www.onvif.org</a> )
Security	Password protection, HTTPS encryption, digest authentication, WS authentication, user access log
Streaming Protocols	IPv4, HTTP, HTTPS, SOAP, DNS, NTP, RTSP, RTCP, RTP, TCP, UDP, IGMP, ICMP, DHCP, Zeroconf, ARP, LLDP, RTP/UDP, RTP/UDP multicast, RTP/RTSP/TCP, RTP/RTSP/HTTP/TCP, RTP/RTSP/HTTPS/TCP, HTTP

## Mechanical

Dimensions Ø x H	232 mm x 222.44mm (9.134" x 8.757")
Weight	2.18 kg (4.85 lbs)
Dome Bubble	Acrylic, clear
Body	Plastic
Housing	Recessed mount
Finish	Plastic, RAL 9003
Tilt	+10° to +67° (depending on position of other camera heads)
Pan	+/-12° to +/-30° (depending on position of other camera heads)
Azimuth	+/- 180°

## Electrical

Power Consumption	13 W with external power or IEEE 802.3af Class 3 PoE
Power Source	VDC: 24 V +/- 10%, 13 W min VAC: 24 V +/- 10%, 19 VA min PoE: IEEE 802.3af Class 3
Power Connector	2-pin terminal block
RTC Backup Battery	3V Manganese Lithium

## Environmental

Operating Temperature	-10°C to 50°C (14°F to 122°F)
Storage Temperature	-10 °C to +70 °C (14 °F to 158 °F)
Humidity	0-95% non-condensing
<b>Certifications</b>	
Certifications	UL cUL CE ROHS WEEE RCM EAC
Safety	UL 60950-1 CSA 60950-1 IEC/EN 60950-1
Electromagnetic Emissions	FCC Part 15 Subpart B Class B IC ICES-003 Class B EN 55022 Class B EN 61000-6-3 EN 61000-3-2 EN 61000-3-3
Electromagnetic Immunity	EN 55024 EN 61000-6-1

# Limited Warranty & Technical Support

Avigilon warrants to the original consumer purchaser, that this product will be free of defects in material and workmanship for a period of 3 years from date of purchase.

The manufacturer's liability hereunder is limited to replacement of the product, repair of the product or replacement of the product with repaired product at the discretion of the manufacturer. This warranty is void if the product has been damaged by accident, unreasonable use, neglect, tampering or other causes not arising from defects in material or workmanship. This warranty extends to the original consumer purchaser of the product only.

AVIGILON DISCLAIMS ALL OTHER WARRANTIES EXPRESSED OR IMPLIED INCLUDING, WITHOUT LIMITATION, ANY IMPLIED WARRANTIES OF MERCHANTABILITY OR FITNESS FOR A PARTICULAR PURPOSE, EXCEPT TO THE EXTENT THAT ANY WARRANTIES IMPLIED BY LAW CANNOT BE VALIDLY WAIVED.

No oral or written information, advice or representation provided by Avigilon, its distributors, dealers, agents or employees shall create another warranty or modify this warranty. This warranty states Avigilon's entire liability and your exclusive remedy against Avigilon for any failure of this product to operate properly.

In no event shall Avigilon be liable for any indirect, incidental, special, consequential, exemplary, or punitive damages whatsoever (including but not limited to, damages for loss of profits or confidential or other information, for business interruption, for personal injury, for loss of privacy, for failure to meet any duty including of good faith or of reasonable care, for negligence, and for any other pecuniary or other loss whatsoever) arising from the use of or inability to use the product, even if advised of the possibility of such damages. Since some jurisdictions do not allow the above limitation of liability, such limitation may not apply to you.

This Limited Warranty gives you specific legal rights and you may also have other rights which vary from jurisdiction to jurisdiction.

**Warranty service and technical support can be obtained by contacting Avigilon Technical Support by phone at 1.888.281.5182 or via email at [support@avigilon.com](mailto:support@avigilon.com).**