

User Guide

Avigilon™ ACC ES HD Recorder

VMA-RPO-4P2 and VMA-RPO-4P4

© 2015 - 2017, Avigilon Corporation. All rights reserved. AVIGILON, the AVIGILON logo, AVIGILON CONTROL CENTER, ACC, and TRUSTED SECURITY SOLUTIONS are trademarks of Avigilon Corporation. Other names mentioned herein may be the trademarks of their respective owners. The absence of the symbols ™ and ® in proximity to each trademark in this document is not a disclaimer of ownership of the related trademark. Avigilon Corporation protects its innovations with patents issued in the United States of America and other jurisdictions worldwide: avigilon.com/patents. Unless stated explicitly and in writing, no license is granted with respect to any copyright, industrial design, trademark, patent or other intellectual property rights of Avigilon Corporation or its licensors.

This document has been compiled and published covering the latest product descriptions and specifications. The contents of this document and the specifications of the products discussed herein are subject to change without notice. Avigilon Corporation reserves the right to make any such changes without notice. Neither Avigilon Corporation nor any of its affiliated companies: (1) guarantees the completeness or accuracy of the information contained in this document; or (2) is responsible for your use of, or reliance on, the information. Avigilon Corporation shall not be responsible for any losses or damages (including consequential damages) caused by reliance on the information presented herein.

Avigilon Corporation
avigilon.com

PDF-4Port-A

Revision: 3 - EN

20170308

This device is provided with a battery powered real-time clock circuit. There is a danger of explosion if battery is incorrectly replaced. Replace only with same or equivalent type recommended by the manufacturer. Discard used batteries according to the manufacturer's instructions.

This equipment is to be connected only to PoE networks without routing to the outside plant.

Table of Contents

Introduction	1
Overview	1
Front View	1
Rear View	2
System Requirements	2
Hardware Installation	3
Supported Network Configurations	4
Configuring the Avigilon Control Center™ Software	5
Starting Up and Shutting Down the Avigilon Control Center Client Software	5
Starting Up the Client Software	5
Shutting Down the Client Software	5
Logging Into and Out of a Site	5
Logging In	6
Logging Out	6
Changing the Administrator Password	6
Connecting Cameras to the Avigilon Control Center System	7
Setting the Recording Schedule	8
Creating a Recording Template	8
Setting Up a Weekly Recording Schedule	9
Setting Data Aging	9
Adding Users and Groups	10
Adding Groups	11
Adding Users	11
Advanced Settings	12
Configuring the Recorder	13
Accessing the Web Interface	13
Status	13
Setup	15
ACC	15
Archives	15
Network	16
Users	16
System	17
Setting the Date and Time	17
Upgrading the Firmware	17
Restarting the System	18

Budgeting PoE Power	18
Assigning a PoE Power Budget	18
PoE Status	19
Device Log	20
Logging Out of the Web Interface	20
Connecting to External Devices	21
LED Indicators	22
Front Panel LEDs	22
Back Panel LEDs	22
Using the Reset Button	23
Restarting the System	23
Restoring Factory Default Settings	23
Troubleshooting — Cannot Reach Default IP Address	24
Limited Warranty and Technical Support	25

Introduction

The Avigilon Control Center™ ES HD Recorder is the all-in-one solution for network video recording. The recorder features:

- A network switch to connect and power IP cameras.
- Built-in server to run the Avigilon Control Center Server Software.
- Local video content storage that can be accessed remotely.

The ACC ES HD Recorder factory default settings allow you to use the recorder immediately after installation, but if you have special requirements, you can use the Avigilon Control Center software or the web interface to customize your settings.

Overview

Front View

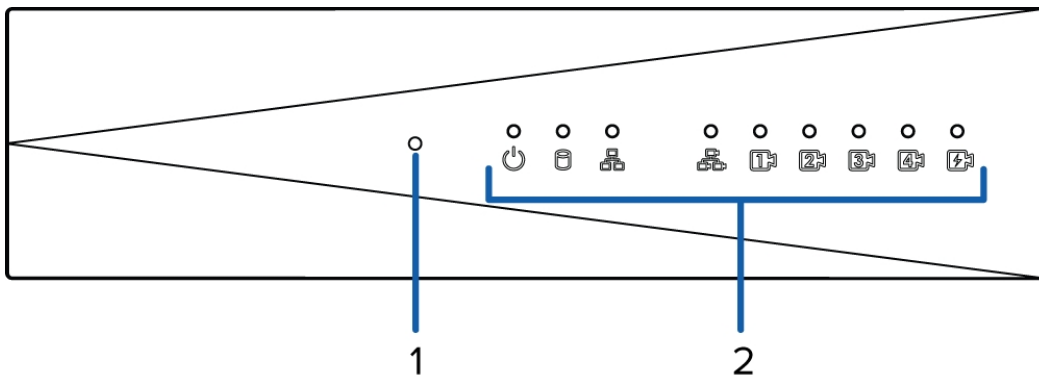

1. **Reset button**

Use this button to physically restart the recorder or perform a factory reset.

2. **Status LED**

Provides information about daily operations. For more information, see *LED Indicators* on page 22.

Rear View

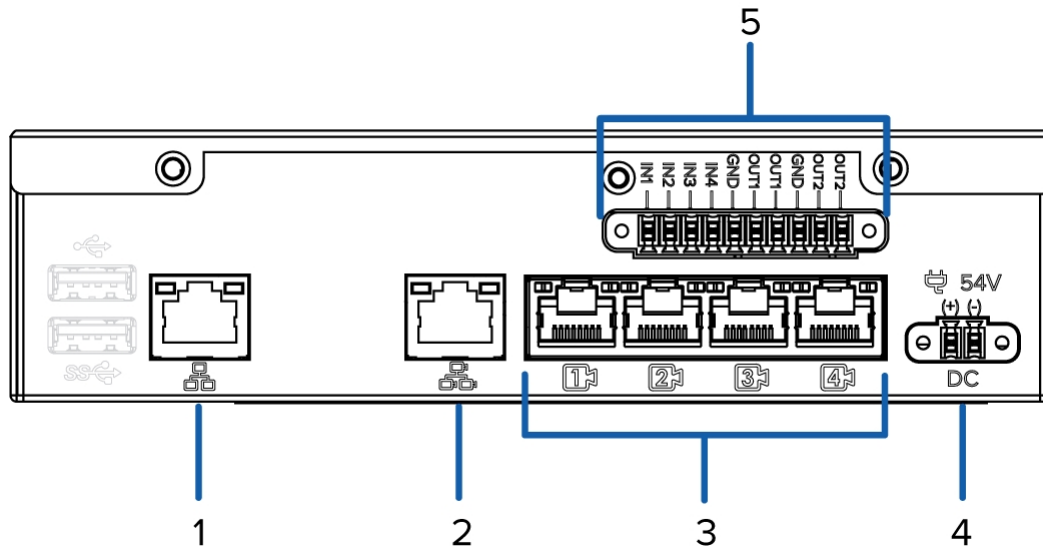

1. Corporate network uplink port

Accepts a 1GbE Ethernet connection to the general network to allow users access to the web interface and connected camera video.

2. Camera network uplink port

Accepts a 1GbE Ethernet connection to the cameras that are connected to the PoE switch component. Can be used to link to other PoE switches and cameras.

3. PoE switch component

Connect cameras to the 10/100 speed PoE switch component to power the cameras and record video.

4. Power connector

Accepts power to the recorder.

5. I/O connector

Provides connections to external input/output devices. For more information, see *Connecting to External Devices* on page 21.

System Requirements

The ACC ES HD Recorder administration settings are managed through a web interface.

The web interface can be accessed from any Windows®, Mac or mobile device using any of the following web browsers:

- Mozilla Firefox® browser version 3.6 or later
- Google Chrome™ browser 8.0 or later
- Microsoft Edge™ browser 25 or later
- Safari® 5.0 or later

- Chrome on Android™ 2.2 or later
- Safari on Apple® iOS 5 or later.
- Windows Internet Explorer® browser version 7.0 or later

NOTE: Your web browser must be configured to accept cookies or the web interface will not function correctly.

Hardware Installation

Complete the recommended procedure for installing the ACC ES HD Recorder:

1. Connect power and wait for the recorder to start up.

Do not connect any other cables until instructed in this procedure.



The status LED turns green to indicate that the recorder is turned on.

2. Connect an Ethernet cable directly from a DHCP enabled port on your configuring laptop to the *camera network* port on the recorder.
3. Open a web browser on the connected laptop and enter this IP address: `https://169.254.100.100`.
If you cannot reach the IP address, see *Troubleshooting — Cannot Reach Default IP Address* on page 24.
4. When you are prompted by the web interface, enter a new password for the administrator username.
The page refreshes and you are prompted to log in.
5. Enter `administrator` as the username and your new password.
The Status page is displayed.
6. From the top of the page, select **Setup**.
7. On the ACC page, click **Install ACC Client** to download and install a copy of the Avigilon Control Center (ACC) Client software to the connected laptop.
8. In the left panel, click **Network**.
9. On the Network page, assign a new hostname for the recorder and select how it obtains an IP address from the corporate network and the camera network. For more information, see *Network* on page 16.
10. Connect an Ethernet cable from the recorder to the corporate network.
11. Disconnect the configuring laptop from the recorder.
12. If required, mount the recorder on a wall using the supplied mounting brackets.



CAUTION — The recorder must be mounted as instructed or any issues that arise will not be covered by the warranty.

- a. Attach the wall mount brackets to the lowest threaded holes on the sides of the recorder.
- b. Position the recorder with the rear panel facing downwards.
- c. Screw the wall mounting brackets to the wall.

- Connect the cameras to the PoE switch component.

NOTE: Allow the recorder 1 to 2 minutes to budget power to all connected devices. The front camera status LEDs initially show that PoE is provided to all connected devices, but the status may change if the system detects that the total power consumption exceeds the PoE limits.

- If required, connect other switches and cameras to the camera network.

Now, you can configure the recorder and cameras for daily operation through the Avigilon Control Center Client software. For more information, see *Configuring the Avigilon Control Center™ Software* on page 5.

Supported Network Configurations

NOTE: Camera Uplink Port does not support dynamically switching DHCP servers.

Network Connections	Camera Web Interface Access	Supported IP Configurations		Notes
		Corporate LAN Uplink	Camera LAN Uplink	
Corporate LAN Uplink only	No	Static or DHCP assigned	Unconnected (leave as DHCP)	Camera LAN Uplink and connected cameras will use Zeroconf IP addresses.
Camera LAN Uplink only	Yes	Unconnected (leave as DHCP)	Static, DHCP-assigned, DHCP-Zeroconf	
Corporate and Camera LAN Uplink	via Camera LAN Uplink only	Static, DHCP-assigned, DHCP-Zeroconf	Static, DHCP-assigned, DHCP-Zeroconf	Corporate and Camera LAN Uplinks must be on different subnets.

Configuring the Avigilon Control Center™ Software

The ACC Client software allows you to view live and recorded video, monitor events, set up alarms, and control user access to the system.

The ACC Client software is the application that you would use on a daily basis. It is also where most of the system configurations are made.



This section includes the recommended steps for setting up your ACC system for the first time.

Starting Up and Shutting Down the Avigilon Control Center Client Software

After you install the ACC Client software, start the application and access the ACC ES HD Recorder.

Starting Up the Client Software

Perform one of the following:

- In the Start menu, select **All Programs** or **All Apps > Avigilon > Avigilon Control Center Client**.
- Double-click  or  desktop shortcut icon.

When you are prompted, log in to your site. You can only access cameras and video after you log in.

Once the application has started, it will automatically display a list of all the sites that are connected to the same network. You will be prompted to log in to all sites.

Shutting Down the Client Software

1. In the top-right corner of the Client software, select  > **Exit**.
2. When the confirmation dialog box appears, click **Yes**.

Logging Into and Out of a Site



After you start the Client software, you are immediately asked to log in to a site. By default, the ACC ES HD Recorder is automatically added to the system as a server within a site of the same name.

The default username is *administrator* with no password.

Logging In

1. Open the Site Login tab. The Site Login tab is automatically displayed if you are launching the Client software for the first time.

To manually access the Site Login tab, do one of the following:

- From the top-right corner of the window, select  > **Log In...**
- From the top-left corner of the application window, click  to open the New Task menu, then click .

2. On the left side of the Site Login tab, select one or more sites.

If the site you want to log into is not shown, click **Find Site...** to discover the site.

3. Enter your username and password for the selected sites.
4. Click **Log In**.

You are logged into the selected sites.

If you want to be notified when new or disconnected sites come online, select the **Notify me when additional sites become available** check box.

If you want to see the login page each time you launch the Client software, select the **Show this tab on startup** check box. If you prefer not to login each time, you can disable this option and configure automatic login from the Client Settings dialog box.

Logging Out





You can log out of one or all sites at any time.

To...	Do this...
Log out of one or select sites	<ul style="list-style-type: none">• In the System Explorer, select one or more sites then right-click and select Log Out.
Log out of all sites	<ol style="list-style-type: none">1. In the top-right corner of the Client, select  > Log Out.2. In the confirmation dialog box, click Yes.

Changing the Administrator Password

After you log in to the ACC system for the first time, it is recommended that you change the default administrator password.

NOTE: These login credentials are different from the web interface user name and password.

1. At the top-left corner of the application window, click  to open the New Task menu.
2. From New Task menu, click .
3. In the Setup tab, click .
4. In the following dialog box, select the administrator user name and click .
5. Click **Change Password...**
6. In the following dialog box, enter a new password and then confirm the new password.
7. Click **OK**.

Tip: If you forget the default administrator password, resetting the password requires restoring the factory default settings on every server in the site. To avoid this issue, it is highly recommended that you create at least one other administrator level user as a backup.



Connecting Cameras to the Avigilon Control Center System

After all the cameras in your system have been physically connected to the ACC ES HD Recorder, you need to connect the cameras to the ACC system so that video can be recorded and indexed for search.



1. In the site Setup tab, click  .
The Connect/Disconnect Cameras... tab is displayed.
2. In the Discovered Cameras area, select one or more devices then click **Connect...**
Tip: You can also drag the device to a server on the Connected Cameras list.
3. In the Connect Camera dialog box, select the server you want the device to connect to.
NOTE: If you are connecting multiple devices, all the cameras must use the same connection settings.
4. If you are connecting a third-party device, you may choose to connect the device by its native driver. In the **Camera Type:** drop down list, select the device's brand name. If there is only one option in the drop down list, the system only supports one type of driver from the device.
5. If the camera supports a secure connection, the **Camera Control:** drop down list is displayed. Select one of the following options:
NOTE: The setting may not be displayed if the camera only supports one of the options.
 - **Secure** — The system will protect and secure the camera's configuration and login details. This option is selected by default.
 - **Unsecure** — The camera's configuration and login details will not be secured and may be accessible to users with unauthorized access.

Cameras with a secure connection are identified with the  icon in the Status column.

6. If it is not displayed, click  to display the Site View Editor and choose where the device appears in the System Explorer.
 - In the  site directory, drag devices up and down the right pane to set where it is displayed.
 - If your site includes  folders, select a location for the device in the left pane. The right pane updates to show what is stored in that directory.
 - If you are connecting multiple devices at the same time, the selected devices must be assigned to the same location.

Tip: If the site you want is not listed, you may need to connect the device to a different server. Make sure the selected server is connected to the site you want.
7. Click **OK**.
8. If the device is password protected, the Camera Authentication dialog box appears. Enter the device's username and password, then click **OK**.

Setting the Recording Schedule

Once all the cameras have been connected, you can set when you want each camera to record video.

By default, all connected cameras are set to record when events are detected by the system. You can skip this procedure if you prefer to keep the default settings.

Before you can assign a recording schedule, you must create a template. The template allows you to assign the same schedule to multiple cameras.

Creating a Recording Template

The events that can be selected for the template depend on the licensed features in your system.

NOTE: Be aware that the system recording schedules use the same timezone as the recorder. For more information about setting the time, see *Setting the Date and Time* on page 17.



1. In the server Setup tab, click . The Recording Schedule dialog box is displayed.
2. Click **Add Template** below the Templates: list.
3. Enter a name for the **New Template**.
4. Click the **Set Area** button, then click or drag the cursor across the **Recording Mode:** timeline to set the types of events that the cameras will record throughout the day. Individual rectangles on the Recording Mode: timeline are colored when they have been selected.

The **Recording Mode:** options include:

- **Continuous** — record video constantly.
 - **Motion** — only record video when motion is detected.
5. To disable recording in parts of the template, click the **Clear Area** button, then click or drag the cursor across the timeline to remove the set recording areas.

6. If cameras are *not* recording in Continuous mode all day, you can set cameras to record reference images between events in the recording schedule.
 - Select the **Record a reference image every:** check box, then set the time between each reference image.

Setting Up a Weekly Recording Schedule

You can set up a weekly recording schedule by applying templates to cameras for each day of the week.



1. In the server Setup tab, click . The Recording Schedule dialog box is displayed.
2. Select a template from the Templates: list.
3. In the Default Week area, click the days of the week this template applies to for each camera.

Default Week							
	Sunday	Monday	Tuesday	Wednesday	Thursday	Friday	Saturday
5.0L-H4A-B2(1008185)	Weekend	Default	Default	Default	Default	Default	Weekend

Figure 1: The Recording Schedule dialog box: Default Week

4. Click **OK**.

Setting Data Aging

Data aging defines how long recorded video is stored and the quality of the video as it ages over time. In the ACC system, the recorded image rate is slowly reduced so that recorded video can be viewed over a longer period of time while still making room for new recordings. You can adjust how long the full image rate video is kept, so that you have the best quality video when you need it.

The amount of data aging that is available depends on the camera you have connected to your system:

- For JPEG2000 or JPEG compression cameras, data aging is available at three rates:
 - **High Bandwidth** keeps recordings at their original quality.
 - **Half Image Rate** discards half of the recorded data to make room for new recordings.
 - **Quarter Image Rate** keeps 1/4 of the original recorded data so that you can still see older video.
- For H.264 cameras that support data aging, data aging is available at two rates:
 - **High Bandwidth** keeps the original high quality video and the secondary stream of low resolution video.
 - **Low Bandwidth** only keeps the secondary stream of low resolution video.

NOTE: The data aging can only occur when the secondary stream is enabled.

- For H.264 cameras that *do not* support data aging, only the **High Bandwidth** video is kept.

By default, the system is set to keep recorded video for the maximum amount of time based on the available storage.

At the bottom of the Recording and Bandwidth dialog is the following statement:

Total record time estimate is based on constant recording

The retention time is determined by the **Max. Record Time** setting and the amortized data rate. Since the system can only provide an estimate of the data rate for the full retention period, the actual retention time can vary from the Max. Record Time setting by up to 30 minutes.

NOTE: The time shown in the Total Record Time column is an estimate only.



1. In the server Setup tab, click

The Recording and Bandwidth dialog box is displayed.

The Data Aging column shows an estimate of the recording time that is available at each image rate, given the amount of space on the recording device.

2. In the Data Aging column, move the sliders to adjust the amount of time video is stored at each image rate.
 - To change the data aging settings for all linked cameras, move the slider for one linked camera and all linked cameras will be updated.
 - To change the data aging setting for one camera, break the camera's link to other cameras by clicking the  icon to the left of its name, then make your changes.
3. In the **Max. Record Time** column, manually enter a maximum record time or select one of the options from the drop down list for each camera.

NOTE: If the time estimated in the Total Record Time column is significantly shorter than what is set in the Max. Record Time column, the camera's actual recording time will be closer to the Total Record Time estimate.

4. Click **OK**.

Adding Users and Groups

If there will be other people using the system, you may want to add them as separate users rather than giving them access through the default administrator account.

Before you can add individual users, you will need to add permission groups that define what users have access to. By default, the system has the following groups:

- **Administrators** — has access to everything in the system.
- **Power Users** — has access to most features in the system except for the ability to import and export settings.
- **Restricted Users** — has access to live video only and can control audio and digital outputs.
- **Standard Users** — has access to live and recorded video, but cannot make any Setup changes.

It is highly recommended that the Administrators group includes at least two users. In the event one administrator user forgets the default administrator password, the second administrator user can be used to reset the password. If you do not have a second administrator user, you may need to completely reset the system.

Adding Groups



1. In the site Setup tab, click
2. In the following dialog box, select the Groups tab and click
3. In the pop-up dialog box, select an existing group to use as a template for your new group, then click **OK**.
4. In the Edit Group dialog box, complete the following:
 - a. Give the new group a name.
 - b. Select a rank for the group from the **Rank:** drop down list. To edit or view the entire Corporate Hierarchy, click .
 - c. Select the required **Group Privileges:** and **Access Rights:** for the group. Clear the check box of any feature or device that you do not want the group to have access to.
5. Select the Members tab to add users to the group.

If a user is added to the group through the Add/Edit User dialog box, the user is automatically added to the group's Members list.

- a. Click .
 - b. Select the users that should be part of this new group. Only users that have been added to the site are displayed.

Tip: Enter the name of a user in the **Search...** field to locate specific users.
 - c. Click **Add**. The users are added to the Members list.
6. Click **OK** to save the new group.

Adding Users



1. In the site Setup tab, click
2. In the Users tab, click .
3. When the Add/Edit User dialog box appears, complete the User Information area.
4. If you don't want this user to be active yet, select the **Disable user** check box. Disabled users are in the system but cannot access the site.
5. In the Login Timeout area, select the **Enable login timeout** check box to set the maximum amount of time the Avigilon Control Center Client software can be idle before the user is automatically logged out of the application.
6. In the Password area, complete the following fields:
 - **Password:** — enter a password for the user.
 - **Confirm Password:** — re-enter the password.
 - **Require password change on next login** — select this check box if the user must replace the password after the first login.
 - **Password Expiry (Days):** — specify the number of days before the password must be changed.
 - **Password never expires** — select this check box if the password never needs to be changed.

7. In the Member Of tab select the check box beside each access group the user belongs to.

The other columns display the permissions that are included in the selected groups.

8. Click **OK**. The user is added to the site.

Repeat this procedure to add all the users that are required.

Advanced Settings

The following list include some advanced settings that you can use to further customize your system. See the application Help files for details about how to configure these settings.

- Adjust camera settings
 - If camera video looks slightly blurry or unclear, you can adjust the camera's Image and Display settings.
 - If you want the camera to record at a different image rate, you can adjust the camera's Compression and Image Rate settings.
 - To reduce the amount of ambient motion detection for a specific camera, you can adjust the Motion Detection settings.
 - To maintain the privacy of certain areas, you can set Privacy Zones in the camera's field of view so that private spaces are never recorded.
- Configure digital inputs and outputs
 - The digital I/O connector on the recorder can be configured as an independent digital I/O device.
 - Use the Digital Inputs and Outputs dialog box to configure the recorder's I/O settings. Once configured, you can use the digital inputs and outputs in alarms and other system actions.
- Alarms
 - Use the Alarms dialog box to create and manage alarms. Once an alarm has been created, you can monitor alarm events in the Alarms tab and in the Avigilon Control Center Mobile App.
- Self-Learning Video Analytics
 - If you have an Avigilon™ self-learning video analytics device, use the Video Analytics Configuration dialog box to configure classified object motion detection. Once configured, you can receive events, trigger alarms, define rules, and record video when specific object motion requires your attention.
- Email notifications
 - You can set up an SMTP email server to send you messages when system events occur.

Configuring the Recorder

The ACC ES HD Recorder can be configured through a web interface that is accessible from any browser on the network. The web interface allows you to configure the recorder server settings like the Avigilon Control Center Admin Tool.

The web interface allows you to configure the network settings, set how the system keeps time, and allows you to remotely restart or upgrade the system.

Accessing the Web Interface

During the installation process, you connected a laptop directly to the recorder and used a special IP address to access the web interface. Once the recorder has been set up and is connected to the corporate network, you can access the web interface following these steps:

1. On a computer with network access to the ACC ES HD Recorder, enter the recorder IP address into a web browser:

`https://<ACC ES HD Recorder IP address >/`

For example: `https://192.168.1.40/`

Tip: If you forgot the IP address that was configured during the installation process, the recorder IP address is listed in the ACC Client software, in the server Setup tab.

2. When you are prompted, enter the web interface username and password.

The username is always `administrator`. The password was configured when you logged in to the recorder for the first time. For more information, see *Hardware Installation* on page 3.

Status

After you log in to the web interface, the first page you see is the Status page. The Status page shows your current system status details.

Tip: Refresh the web browser to see the latest status.

Feature	Description
Avigilon Control Center Information	
ACC Site Name	The name of the site that the recorder is connected to.
ACC Server Name	The name of the recorder in the site.
ACC Server Status	The status of the ACC Server software.
ACC Server Version	The version of the ACC Server software.
HDD Information	
Disk	The name of the hard drive disk.
Capacity	The capacity of the hard drive disk.

Feature	Description
Status	The status of the hard drive disk.
Device Information	
Product Name	The product name of this recorder.
Part Number	The display part number of this recorder.
Serial Number	The serial number of this recorder.
Device UUID	The UUID of this recorder.
System Information	
System Status	<p>Lists the current recorder status. The statuses can be:</p> <ul style="list-style-type: none"> • Ready — the system is ready for normal operations. This is the normal system status. • Disk Startup — the hard drives are starting up. • Reinstalling Factory Firmware — if you choose to restore the factory default settings, the system displays this status when it reinstalls the factory firmware. • Firmware Upgrade Required — you must download the latest firmware and upgrade the system to continue normal operations. • Firmware Check — the system is checking the uploaded firmware package before installing the upgrade. • Hard Disk Error — a system hard drive error occurred. Try rebooting the system to resolve the issue.
Firmware Version	The system firmware version.
MAC Address (LAN Corporate)	<p>The MAC address for the corporate network.</p> <p>Users would typically connect to the recorder through this network port from the ACC Client software.</p>
MAC Address (LAN Camera)	<p>The MAC address for the camera network.</p> <p>This is the network port that allows you to connect to other cameras</p>
License Information	
Server ID	The ACC Server software ID.
Edition	The ACC license edition.
Camera Channels	The number of camera channels included in the license.
Max Clients	The maximum number of simultaneous client connections allowed by the license.
POE Port Status	
Port	The port number in the PoE switch component.
Link Status	The network status of the device that is connected to the port.
Power Status	The power status of the device that is connected to the port.
Uplink Status	
Uplink	The name of the network port that the uplink is connected to.

Feature	Description
Speed	The speed of communication on the network.
Status	The status of the network connection.

Setup

To configure your device, click the **Setup** link on the left side of the top banner.

ACC

When you click **Setup**, the first page you see is the ACC page. Use the left link pane to navigate through the Setup screens.

The ACC page allows you to control how the recorder communicates with network clients. You can perform any of the following tasks:

To...	Do this...
Install the ACC Client software.	Click Install ACC Client to download and install the software to the computer you are using to access the web interface.
Shut down the ACC Server software.	Click Stop ACC Services . NOTE: Stop the ACC Server software before you shut down the recorder.
Start up the ACC Server software.	After the ACC Server has shut down, click Restart ACC Services .
Format the disk drives.	Click Reinitialize Storage to delete all configuration and recorded video data.
Change the UDP and TCP ports used to communicate with the ACC Server software.	In the Service Ports and RTP Ports area, change the Base Port that is used to access the recorder. Click Apply to save your changes. These changes can only take effect after the system restarts. When you are prompted, allow the system to restart.

Archives

You must enable video archiving before you can use the archiving feature in the ACC Client software.

The Archives page allows you to enable the video archiving feature and set the network location where archived video is saved.

1. Select the **Enable Archive** check box.
2. From the Network Protocol: drop down list, select one of the following:
 - **CIFS** — Common internet file system. The network path is typically in this format: *//<hostname or IP> / <path>*
 - **NFS** — Network file system. The network path is typically in this format: *<hostname or IP> : <path>*
3. In the **Network Path:** field, enter the path to the preferred video archiving location.
4. If the network location requires authentication, select the **Authentication** check box then enter the

credentials in the Username and Password fields.

5. Click **Apply**.

Network

On the Network page, you can change how the recorder connects to the network. The recorder supports two network connections: one for a corporate network and one for a camera network.

The corporate network is the network that typically provides users with access to the recorder. Users who monitor video through the ACC Client software would connect to the recorder through this network.

The camera network is a closed network that typically only contains cameras. This reduces the amount of interference with video recording.

For more information about the network connections, see *Supported Network Configurations* on page 4.

On the Network page, you can perform any of the following:

To...	Do this...
Change the hostname.	<p>At the top of the page, enter a new name in the Host Name field then click Apply.</p> <p>The default hostname is provided in this format:</p> <p><i><Model>-<Serial Number>.AVIGILON</i></p> <p>e.g. VMA-PRO-4P2-KFO0004731.AVIGILON</p>
<p>Set how the recorder obtains an IP address for each network.</p> <p>NOTE: The Corporate Network Uplink Port and the Camera network Uplink Port must be on different subnets.</p>	<p>In the Uplinks area, select one of the following for the LAN: Corporate and LAN: Camera network connections:</p> <ul style="list-style-type: none"> • Obtain an IP address automatically: select this option to connect to the network through an automatically assigned IP address. • Use the following IP address: select this option to manually assign a static IP address. <p>Enter the appropriate values in the following fields: IP Address., Subnet Mask: and Default Gateway.</p> <p>Click Apply to save your changes.</p>
Set how the recorder obtains a named address from a DNS server.	<p>In the DNS Lookup area, select one of the following options:</p> <ul style="list-style-type: none"> • Obtain DNS server address automatically select this option to allow the system to automatically select DNS server and receive a named address. • Use the following DNS server addresses: select this option to assign specific DNS servers for addressing the recorder.
Restore system default network settings.	At the bottom-right corner of the page, click Restore Defaults .

Users

The Users page allows you to change the default administrator password.

NOTE: You cannot change the default *administrator* username on the web interface, only the password.

1. To change your password, confirm your identity by entering your current password in the **Old Password:** field.
2. Enter the new password in the **New Password:** field.
3. Re-enter the new password in the **Confirm New Password:** field.
4. Click **Apply** to save the new password.

NOTE: If you forget your password, you must reset the recorder to the factory default settings to reset the administrator password. This will also format the hard drives and delete the configuration data and recorded video. For more information on performing a factory restore, see *Restoring Factory Default Settings* on page 23.

System

On the System page, you can change your time settings, upgrade firmware and reboot the device.

Setting the Date and Time

In the Device Time and NTP Settings area of the System page, you can customize how the recorder keeps time.

- It is recommended that the recorder keeps time through a Network Time Protocol (NTP) server. To use this option, select the **Use NTP Server** option.
 - **DHCP** — select this option to automatically use an existing NTP server in the network.
 - **Manual:** — select this option then enter the address of the NTP server in the **NTP Server:** field.

NOTE: If you have multiple ACC systems running on the network, make sure they all synchronize with the same NTP server.

- Select the **Set date and time from browser time** option to sync time with your browser whenever you access the web interface.
- Select the **Change timezone** check box then select the local time zone.

Click **Apply** to save your settings.

Upgrading the Firmware

You may want to upgrade the recorder firmware to use the latest features, or if the firmware becomes corrupted. Choosing to upgrade corrupted firmware helps you avoid reverting to the factory default settings. When you revert to the factory default settings, all of the configured settings are lost and all recorded video is deleted.

To upgrade the firmware, download the latest version of the firmware `.fimage` file from the Avigilon website (avigilon.com).

1. In the Upgrade Firmware area of the System page, browse and locate the downloaded firmware file.
2. Click **Upload**.
3. Allow the system to reboot when the following message is displayed:

The device will be rebooted during the firmware update. Are you sure you want to continue?

The upgrade file is uploaded to the recorder. A progress bar displays the upload status.

As the system upgrades, a blue progress message is displayed at the bottom of the screen. When the upgrade is complete, the message turns green. Refresh the page periodically to receive the latest status update.

Once the reboot is complete, you can return to normal operations.

If you are only able to access the web interface and none of the other system features, run the same firmware upgrade again or revert to the factory default settings.

NOTE: If an error occurs during the upgrade process or if the firmware becomes corrupted, the system may revert to the factory default settings as the system reboots.

Restarting the System

You can restart the recorder remotely from the web interface.

- At the bottom of the System page, click **Reboot**.

Budgeting PoE Power

The recorder PoE switch component can output a total of 60 W of power to the connected devices. Each PoE port is capable of outputting 16 W to standard PoE devices, and 30 W to PoE+ devices. This typically means that the recorder can support 4 standard PoE devices and up to 2 PoE+ devices. Advanced users can adjust the PoE power budget for each port to consistently accommodate 4 cameras.

If you choose to manually adjust the PoE budget at each port, be aware that you must also account for potential power loss in the cable. Unless the amount of power loss in the cable is known, use the following estimates:

- If the device uses less than or equal to (\leq) 16 W — expect 2.5 W of power loss.
- If the device uses more than ($>$) 16 W — expect 4.5 W of power loss.

To calculate the recommended power budget for each port, use the following equation:

$$\text{Power budget} = \langle \text{Camera power consumption} \rangle + \langle \text{Expected cable power loss} \rangle$$

For example, you want to connect the following 4 cameras:

2 x HD dome cameras	$(9\text{ W} + 2.5\text{ W}) \times 2$	= 23 W
1 x HD PTZ camera	$25.5\text{ W} + 4.5\text{ W}$	= 30 W
1 x HD micro dome	$4\text{ W} + 2.5\text{ W}$	= 6.5 W
	Total	= 59.5 W

The total power consumption of the 4 cameras is within the PoE switch component limits.

NOTE: If you miscalculate the required power for a PoE port, the connected camera may be shut down if total power output exceeds 60 W.

Assigning a PoE Power Budget

On the POE page, the first row is for Port 1 and the other ports are listed in order from top to bottom. On the recorder, the ports are listed in order from left to right.

You can assign PoE power budget in the following ways:

Option	Description
Disable power output for a port.	<p>From the Power drop down list, select Off.</p> <p>Once disabled, the port no longer outputs power but can act as a standard network connection for any device.</p> <p>Tip: You can also use this feature to remotely restart the camera. After you set the Power setting to Off, wait for the camera to power off then change the Power setting to On.</p>
Disable PoE Plus on the ports that are connected to standard PoE devices.	<p>From the POE+ drop down list, select Disabled.</p> <p>Once disabled, the port only supports PoE 802.3af with 16 W of maximum power output.</p>
Manually assign a specific PoE budget.	<p>In the Budget column, enter a power budget value in watts. Make sure the budget includes potential power loss at the cable. For more information, see <i>Budgeting PoE Power</i> on the previous page.</p> <p>When you click the Budget field, the following note is displayed:</p> <p><i>Note: Set to maximum power. Refer to the user guide for guidance.</i></p> <p>By default, the Budget field budgets a maximum of 30 W when the POE+ setting is Enabled, and 16 W when it is Disabled. Depending on the POE+ setting, you can enter any value within the maximum power budget.</p>
Revert to the factory default settings.	<p>Click Restore Defaults.</p> <p>The factory default settings are:</p> <ul style="list-style-type: none"> • Power — On. • POE+ — Enabled. • Budget — automatically assigned.

Be aware that your settings are not implemented until you click **Apply Changes**. Until the changes are implemented, you can click **Clear Changes** at any time to revert your changes.

After you click **Apply Changes**, allow the system to reboot when the following message is displayed:

Applying changes may reboot cameras. Do you want to continue?

As the settings are implemented, this message is displayed:

Resetting camera power settings.

This will take 90 seconds to complete.

The web interface automatically refreshes the screen and displays the updated settings after it finishes applying the new power settings.

PoE Status

Tip: If a device is disconnected then reconnected to the recorder, you may need to refresh this page to view the latest status and budget values.

The POE page displays a status for each port in the Status column. Statuses include the following:

- *No device connected* — there is no Ethernet cable connected to the port.
- *Operating normally* — a PoE device is connected to the port and is operating normally.
- *Unpowered device* — a device is using the port for a network connection only.
- *Port is powered off* — a PoE device is connected to the port but is not receiving power. This status typically occurs when the port is overcurrent, device is requesting more power than budgeted, etc.

At the bottom of the POE page is the overall power budget status. The status typically says:

#W Currently Budgeted (note: The total budget cannot support more than 64W. Devices will turn off automatically when exceeded. To reduce consumption, turn off POE+ for one or more ports, or use cameras that require less than budgeted amount.)

When the message is **red**, the PoE switch component is over the power budget and one or more devices may have powered down from insufficient power.

Device Log

The Device Log page allows you to view the recorder system logs. The logs are typically requested by Avigilon Technical Support to help resolve an issue.

By default, the page displays 100 warning messages from the ACC Server Logs.

You can filter the logs to display the information that you need:

1. In the **Type:** drop down list, select the type of application log that you need. The options are:
 - ACC Server Logs
 - Fcp Logs
 - System Logs
 - Boot Logs
 - Nginx Error Logs — web interface logs
2. In the **Minimum Log Level:** drop down list, select the minimum severity of the log messages that you want to see. The options are:
 - Error
 - Warning
 - Info
3. In the **Maximum Number of Logs** drop down list, select the number of log messages you want to display each time.
4. Click **Update** to display the logs that match your filters.

Logging Out of the Web Interface

1. To log out of the web interface, click the **Logout** link on the left side of the top banner.
2. When the browser asks "Are you sure?", confirm that you want to log out of the web interface.

Connecting to External Devices

External devices are connected to the recorder through the I/O terminal. The pinout for the I/O terminal is shown in the following diagram:

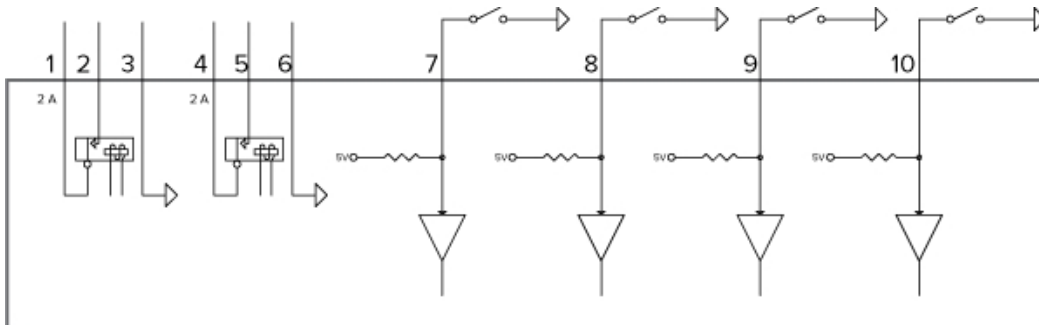





1. OUT 2 (Relay Output) — Form-A dry contact outputs. When active, terminals are connected. Terminals are open when inactive.
Maximum load is 30 V, 2 A or 200 V, 250 mA.
2. OUT 2
3. Ground (GND)
4. OUT 1 (Relay Output) — Form-A dry contact outputs. When active, terminals are connected. Terminals are open when inactive.
Maximum load is 30 V, 2 A or 200 V, 250 mA.
5. OUT1
6. GND
7. IN 4 (Alarm In) — Active-Low inputs. To activate, connect the Input to the Ground pin (GND). To deactivate, leave disconnected or apply between 3 – 15 V.
8. IN 3
9. IN 2
10. IN 1



LED Indicators

The following list describes what the LEDs on the ACC ES HD Recorder indicate.

Front Panel LEDs

Icons	LED Status	Description
	Green	Device is powered and running.
	Orange	Device is restarting.
	Orange - blinking	Factory restore button pressed.
	Green	Hard disk drive is connected.
	Red	Hard disk drive connection has an error.
	Green	Camera is using the switch for a network connection and Power over Ethernet (PoE) power.
	Orange	Camera is only using the switch for a network connection.
	Orange - slow blinking	Port off due to failure.
	Alternating Green - Orange	Port off due to system over power budget.
	Orange	GigE network link is present.
	Green	10/100 network link is present.
	Orange	Switch component has reached its PoE output capability.

Back Panel LEDs

Icons	LED Status	Description
	Green	Network activity is present.
	Orange	On for GigE speed. Off for 10/100 speed.
	Green	Network activity is present.
	Orange	On for 100M speed. Off for 10M speed.

Using the Reset Button

The reset button is located at the front of the recorder and is the small unlabeled circle to the left of the System Status LED. For more information, see *Front View* on page 1

The reset button provides two functions:

- Restart the system — If the recorder encounters a system error, you can force it to restart.
- Restore the factory default settings — If the ACC software no longer functions as expected, you can reset the recorder to its factory default settings. All configuration settings and recorded data will be deleted.

NOTE: When you use the reset button, the recorder must be powered.

Restarting the System

If the recorder encounters a system error and you are unable to access the web interface, you can try to resolve the issue by restarting the system from the physical recorder.

- Using a straightened paperclip or similar tool, gently press and release the reset button.



CAUTION — Do not apply excessive force. Inserting the tool too far will damage the recorder and void the warranty.

Important: Do not hold down the reset button for too long or you will revert to the factory default settings.

Restoring Factory Default Settings

If the ACC Server software no longer functions as expected or if you've forgotten your administrator password, you can reset the recorder to its factory default settings.

NOTE: Restoring to the factory default settings will delete all configuration settings and recorded video.

1. Using a straightened paperclip or similar tool, gently press and hold the reset button.



CAUTION — Do not apply excessive force. Inserting the tool too far will damage the recorder and void the warranty.

2. Do not release the button until the  LED is orange and starts to blink.

Troubleshooting — Cannot Reach Default IP Address

If the 169.254.100.100 address is not accessible during the hardware installation, it is because the network cable was connected to the corporate network port rather than the recommended camera port.

You can choose to restore the 169.254.100.100 address by reverting the recorder to its factory default settings. For more information, see *Restoring Factory Default Settings* on the previous page.

Or, you can avoid reverting to the factory default settings by discovering the DHCP assigned IP address from the ACC Client software:

1. Download and install the ACC Client software on to the configuration laptop.

The ACC Client software can be downloaded from the Avigilon website: [avigilon.com](https://www.avigilon.com).

2. Launch the ACC Client software.
3. Log into the site that uses this naming convention: VMA-PRO-4Px-xxxxxxxxx.AVIGILON.

The default username is *administrator*, with no password.

NOTE: The username and password for the ACC application is separate from the credentials for the recorder web interface. To change the password for the ACC application, see *Changing the Administrator Password* on page 6.

4. Display the server Setup tab.

At the top of the window, the recorder IP address is displayed.

5. Open a web browser and enter the IP address in this format: `https://<IP address>`.
6. Continue the remaining steps for installing the recorder.

Limited Warranty and Technical Support

Avigilon warranty terms for this product is provided at [avigilon.com/warranty](https://www.avigilon.com/warranty).

Warranty service and technical support can be obtained by contacting Avigilon Technical Support: [avigilon.com/contact-us/](https://www.avigilon.com/contact-us/).